

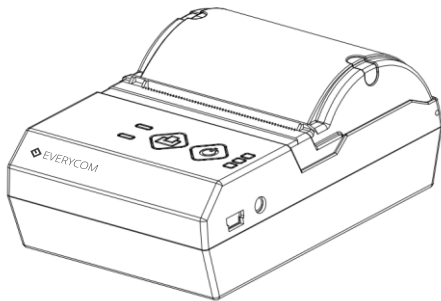

EVERYCOM **EC200**

THERMAL RECEIPT PRINTER



USER MANUAL

Please read this manual carefully before using the printer,
we recommend that you keep this user manual for future reference.

ABOUT THIS USER MANUAL

We thank you for your purchase of Everycom EC200 Thermal receipt printer. This user manual will guide you through on how to use this printer. Please read this user manual carefully before using the printer. We also strongly recommend that you keep this user manual for future reference and do not throw it away.

NOTE

Due to our constant efforts to improve and upgrade the product's function and performance, Everycom reserves the right to change the hardware and software specifications in the manual without prior notice. If you find any errors or omissions in the contents of this manual, please tell us or our agent, we will take necessary action ASAP. Without the prior permission of our Everycom, the contents of the relevant manual provided with the product shall not be revised, reproduced, or transmitted, transcribed or stored etc.

STATEMENT

This printer is TYPE A product, may cause radio interference in the living environment, in any such possible case, the user need to take effective protection measures from protection from interference.

SAFETY TIPS

- Do not disassemble the printer personally, for any service related query please contact Everycom Support.

- While charging if you see smoke coming out of battery / power adaptor or there is bad smell, please shut off the power supply immediately. Keep safe distance from the printer and wait for few minutes before inspecting the situation closely. If printer is very hot or battery had smoke or bad smell, please take out the battery from printer (Caution : Battery may be very hot, avoid burns).
- Please do not use this printer at gas station, fuel station or warehouse containing inflammable goods.
- While charging make sure that printer and power adaptor both have proper ventilation and room temperature is between -5°C ~ 40°C , please only use our standard power adaptor. Using third party unauthorized power adaptor may damage the product and will also void the warranty.
- Please do not open the paper cover while printer is printing, doing so may cause unexpected error or may even cause damage to the printer.
- To avoid burn, please do not touch the print head right after the printer finished printing.
- In order to ensure quality printing and long life of printer, please use quality thermal paper only.
- Please do not use dissoluble substances such as Benzene, Thinner or Alcohol wipe to clean the printer casing, also please do not let printer in contact with corrosive chemicals and detergents to avoid damages.

- Please remove the battery from printer if you plan not to use printer for long time, please store printer and battery separately.
- Before inserting or removing the battery from printer, please make sure printer is properly shutdown and power adapter is not connected to printer.
- Thermal prints fade away, if you don't want this to happen, please use long term thermal paper.
- The printer is only suitable for using below 2000M altitude.
- The printer is only suitable for use in non-tropical region/climates.

PRECAUTIONS TO TAKE WHILE USING BATTERY

- Please read this manual and marking label on the battery carefully.
- Please charge the battery indoor, make sure the room temperature is within recommended limits. Charging in high temperature environment may cause over heating of battery and may result in explosion of battery.
- Please do not try disassembling the battery, doing so will cause short circuit or electrolyte leakage. If this electrolyte went into eyes, it may cause permanent blindness. If accidentally such leakage went into eyes, please rinse immediately and rush to hospital for treatment.

- Squeezing, vibrating or shaking battery is strictly prohibited as it may cause short circuit and battery may explode.
- Please do not put battery into water or other liquid, this may cause short circuit and may result in explosion of battery.
- Please do not expose battery to the sun, please do not use in high humidity environment such as bathroom, sauna room etc..
- Please keep the battery away from reach of children.
- Please immediately discontinue using battery if found battery to be in deformed shape, have leakage or any other abnormal findings.

PRECAUTIONS TO TAKE WHILE USING POWER ADAPTOR

- Before using the power adaptor, please read this manual and marking label on the surface of power adaptor carefully.
- If the power adaptor is exposed to water or other conductive liquid, please cut off the power supply immediately.

- Do not disassemble or modify the power adaptor. It is strictly prohibited to use the power adaptor whose power cable is damaged , this may cause damage to power adaptor and can even lead to electric shock, fire or other hazards.
- Please do not short-circuit the power adaptor or vigorously shake the power adaptor to avoid any dangerous situations.
- Please do not use the power adaptor in high humidity environment such as bathroom, sauna room etc..
- Please keep the power adaptor in safe place and out of reach of children.

APPLICATION AREA

- Water and electricity meter reading and receipt printing
- Transport & logistics receipt printing
- Mobile government, police receipt printing
- Taxi bill printing and much more..

WHAT'S IN THE BOX

- 1 X EC200 Thermal Receipt Printer
- 1 X Power Adaptor
- 1 X Battery
- 1 X Paper Roll
- 1 X USB Cable
- 1 X User Manual

OPTIONAL ACCESSORIES

- 1 X COMLine
- 1 X Carry Case
- 1 X Driver CD

PRODUCT FEATURES

- Easy paper loading, simple and convenient to operate
- Support Gb18030 big font, easy to print uncommon characters.
- Multi-lingual printing, worldwide usability.
- Support for download and print of logo and graphics
- Built-in data buffer, print and receive data at the same time.
- Support character zoom, rotation, adjustable line spacing
- Compatible with ESC/POS instruction set
- Extended battery life, Smart power saving mode.
- Beep alarm for error or no paper.
- 1.5M concrete floor anti-fall body
- Support Windows, Linux, Android and iOS operating systems

TECHNICAL SPECIFICATIONS

Item		Parameter
Printer parameter	Printing Method	Thermal Line
	Effective Printing Width	48mm
	Resolution	384 dots/line(8dots/mm, 203dpi)
	PrintingSpeed	70mm/S
	Interface	USB, Serial, Bluetooth
	Line spacing	3.75mm (Can adjust line spacing by command)
	Line No.	Font A:32character /Line Font B:42character/Line Simple/TraditionalChinese:16characters/Line
	Character	The standard GB18030 simplified / traditional Chinese characters library
	Character Size	ANK character , Font A : 1.5×3.0mm (12×24dots) Font B : 1.1×2.1mm (9×17 dots) Simplified/Traditional: 3.0×3.0mm(24×24 dots)
Barcode character	Extended character set	PC437/Katakana/PC850/PC860/PC863/PC865/WestEurope/Greek/Hebrew/EastEurope/Iran/WPC1252/PC866/PC852/PC858/IranII/Latvian/Arabic/PT15 1,1251/PC737/WPC/1257/ThaiVietnam/PC864/PC1001/(Latvian)/(PC1001)/(PT151,1251)/(WPC1257)/(PC864)/(Vietnam)/(Thai)
	Bar code	1D.Bar code : UPC-A/UPC-E/JAN13(EAN13)/JAN8(EAN8)CODE39/ITF/CODABAR/CODE 93/CODE128 2D.Bar code : QR CODE

TECHNICAL SPECIFICATIONS

Item		Parameter
Graphics printing	Graphics printing	Supports bitmap download and print (support each bitmap size Max.8K, download up to 5pcs)
Power saving Mode	Smart power saving	Support
	Variable speed printing	Support
	Consumption	Support
	Dormancy	Support
Detection	Sensor	Lack of paper detection
Paper	Type	Thermal
	Width	57.5±0.5mm
	Diameter	≤40mm
Commands	Commands	ESC/POS
Power	Type	Rechargeable Lithium polymer battery
	Capacity	2000mAh/7.4V
	Charger	9.0V/2A
Physical features	Weight	200G
	Dimension	114*80*50(MM)
Environment	Operating	Temp : 5 ~ 45°C , Humidity: 10 ~ 80%
	Storage	Temp : -10 ~ 50°C , Humidity: 10 ~ 90% (No Dew)
Reliability	Print head life	50KM (Printing Density≤12.5)
Software	Driver	Android,IOS,Linux,Win2000,Win2003,WinXP,Win7,Win8,Win8.1

KNOW YOUR PRINTER

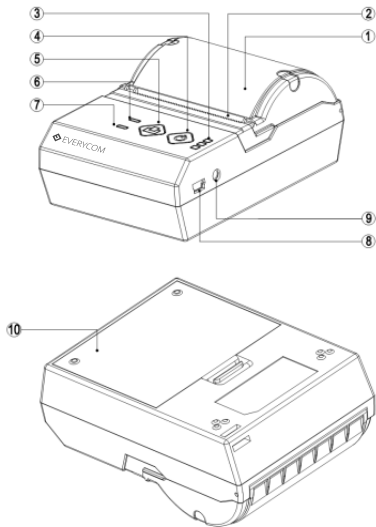

1. Thermal paper holder
2. Paper window
3. Power indicator
4. Power button
5. Feed button
6. Error indicator
7. Battery charge level indicator
8. USB (COM) port
9. Power input (Charging port)
10. Battery cover

BUTTON NAME, INDICATOR & FUNCTIONS

1. (BATTERY CHARGE LEVEL) INDICATOR

If 3 Blue lights, this indicates that battery is full, if only 1 blue light then that means battery low.

2. (ERROR) INDICATOR

This indicator keeps flashing in red light if paper cover is not closed properly or printer is out of paper or have other system errors while printing.

3. (CHARGE) INDICATOR

While charging the battery this indicator will show red color light, while on fully charged it will show blue color light. Upon seeing blue color light, power adaptor can be disconnected and printer can be used normally.

4. (FEED) BUTTON

This button is used to feed paper.

PREPARATION BEFORE USE (BATTERY INSTALLATION)

Insert the battery into the battery holder of printer as show in the image here.

Note : Please charge the battery for at least 12 hours when using it for the first time, after that please do normal charging in future.

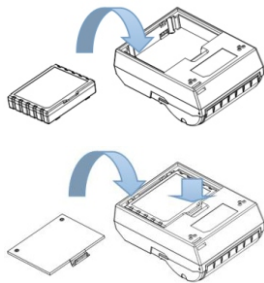

HOW TO : LOAD PAPER

EC200 Thermal receipt printer uses 58mm thermal paper roll, please make sure you have the correct paper roll for the printer.

1. Remove the seal on the thermal printing paper.

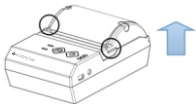
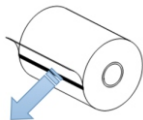

2. Firmly hold the top flip cover of the printer with your forefingers and pull the cover upward direction to open the flip cover.

3. Put the thermal paper roll in the paper holder according to this image.



4. Pull a little portion of paper outside the paper holder. Close the flip cover and tear off excess paper.

Note: Be careful on the roll direction, if reverse direction, printer won't be able to print the content.

BASIC OPERATIONS

1. POWER ON

Continue to press the power button for 3 seconds, printer will start.

2. SHUTDOWN

If printer is already powered on, continue to press the power button for 3 seconds, printer will shutdown.

3. SELF TEST

Make sure the printer have paper loaded already and printer is properly shutdown.

Press the power button and feed button at the same time, when printer feeds little bit of the paper, release the power button and feed button at the same time, printer will print the self test page.

COMMUNICATION

This printer supports following ways of communication

- USB communication via standard USB 2.0 protocol
- COM communication (Optional) via COM line
- Bluetooth communication via dual mode Bluetooth v3.0/v4.0

USB COMMUNICATION

USB interface of this printer uses standard USB 2.0 communication protocol and can be used to easily connect the printer to Windows / Android / iOS / Linux devices which are equipped with corresponding drivers and SDK.

Note: Please download the necessary SDK or driver from official website or request your supplier to provide.

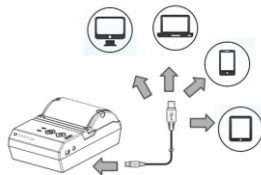
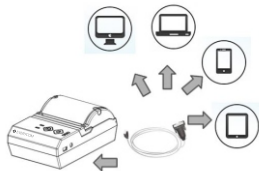

COM COMMUNICATION (OPTIONAL)

Optional COM interface available, printer uses standard COM communication protocol. This supports multi-platform interconnection and baud rate can be adjusted as well.

BLUETOOTH COMMUNICATION

This printer supports dual mode Bluetooth v3.0 / v4.0 for wireless communication and can be easily connected to Windows / Android / iOS devices. The wireless range is up to 15M.

Default pairing password: 12345

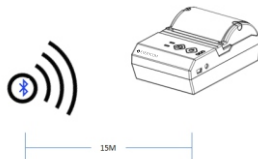

HOW TO : REPAIR & MAINTENANCE

1. Printer casing & paper holder cleaning : Use a wet cloth gently wipe the outer surface and paper holder of the printer.
2. Print core cleaning : Printer core should be cleaned time to time especially if the printing quality is declining. cleaning method is as follows. Use clean cotton dipped in anhydrous alcohol and gently wipe the printer core ceramic part until clean enough.
3. If notice water inside the printer, please immediately disconnect the power supply of printer and let the printer dry out naturally.

FAILURE ANALYSIS

Failure Phenomenon	Failure Cause	Solution
No Power Status Light / No Response	Battery no charge	Please connect the power adaptor and charge the battery.
Printer shutdown automatically	Battery no charge	Please connect the power adaptor and charge the battery.

Failure Phenomenon	Failure Cause	Solution
Error indicator flashing & beep sound	1. Printer out of paper. 2. Print head overheat. 3. Top flip cover not closed properly.	1. Load paper correctly. 2. Open the top flip cover & let the heat dissipate fully before resuming printing. 3. Close the flip cover properly.
Blank print out	Thermal paper installed incorrectly (Reverse)	Please install the thermal paper in correct direction.
Fuzzy Print	Dirty print head	Use clean cotton dipped in anhydrous alcohol and gently wipe the printer core ceramic part until clean enough.

 EVERYCOM - **INNOVATING BUSINESS**